



The Ultimate in Fall Protection

INSTRUCTION MANUAL	
ANSI Z359.14 Class B	
ANSI A10.32	OSHA

SEALED-BLOK™ SELF-RETRACTING DEVICES
Model Numbers: (See Figure 1.)

Figure 1 – Sealed-Blok™ Rope Self-Retracting Lanyards with Retrieval



Model	Retrieval	Housing	Lifeline ¹	Range ²	Capacity	L	W	D
3400840	✓ + Bracket	Aluminum	1/4" Diameter 12 Strand Technora® Rope with 2000181 Stainless Steel Swiveling Self-Locking Snap Hook	30 ft (9.1 m)	420 lbs (189 kg)	13.3 in (34 cm)	10.4 in (27 cm)	6.9 in (18 cm)
3400843	✓ + Bracket	Aluminum	1/4" Diameter 12 Strand Technora® Rope with 2000181 Stainless Steel Swiveling Self-Locking Snap Hook	55 ft (16.5 m)	420 lbs (189 kg)	16 in (41 cm)	9.9 in (25 cm)	6.7 in (17 cm)

1 - Sealed-Blok Rope Self-Retracting Lanyards do not include FAST-Line Replacable Lifeline capabilities.

2 - In addition to the Working Range, there is a 2 ft (61 cm) Emergency Reserve.

+ **Bracket** - Includes Mounting Bracket

Hook	Description	Material	Gate Strength	Throat Size
2000181	Swiveling Self-Locking Snap Hook with Impact Indicator	Stainless Steel	3,600 lbs (16 kN)	3/4 in (1.9 cm)

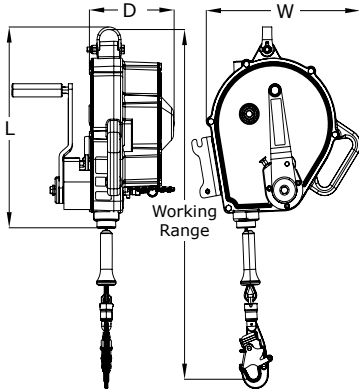

Technora® Rope Lifeline Tensile Strength:	7,300 lbs (32.4 kN)
Maximum Arrest Force:	1,350 lbs (6 kN)
Average Arrest Force:	900 lbs (4 Kn)
Maximum Arrest Distance:	42 in (1.1 m)
Average Locking Speed:	4.5 ft/s (1.4 m/s)

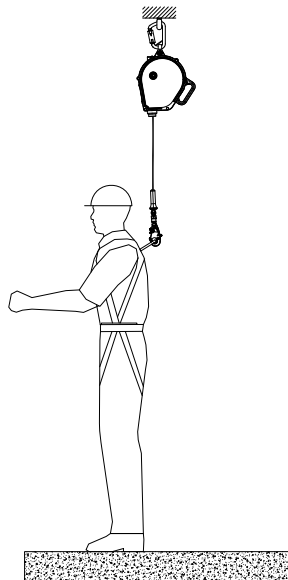

Fall Arrest

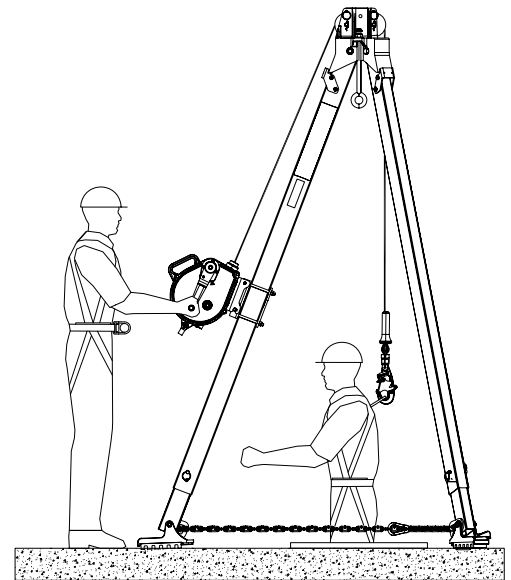

Confined Space Entry/Rescue

⚠ WARNING: This product is part of a personal fall arrest or rescue system. The user must follow the manufacturer's instructions for each component of the system. These instructions must be provided to the user of this equipment. The user must read and understand these instructions before using this equipment. Manufacturer's instructions must be followed for proper use and maintenance of this equipment. Alterations or misuse of this product or failure to follow instructions may result in serious injury or death.

❗ IMPORTANT: If you have questions on the use, care, or suitability of this equipment for your application, contact Capital Safety.

❗ IMPORTANT: Before using this equipment, record the product identification information from the ID label in the 'Inspection and Maintenance Log' at the back of this manual.

DESCRIPTION:

Figure 2 identifies key components of the Sealed-Blok™ Self-Retracting Lanyards (SRLs). The Sealed-Blok Rope SRLs covered in this Instruction Manual are non-replaceable Technora® Rope Lifelines (A) which retract into a sealed aluminum Housing (B). They hang from overhead anchorage by a Carabiner attached through the Anchorage Handle (C) on the top of the SRL. A Self-Locking Snap Hook (D) on the end of the Lifeline attaches to the designated Fall Arrest connection on a Full Body Harness. A Bumper (E), equipped with an i-Safe RFID Tag, protects the Wire Rope and Ferrules securing the Snap Hook from abrasion and corrosion.

SEALED-BLOK™ 3-WAY EMERGENCY RETRIEVAL SRL-R MODELS: The Sealed-Blok Rope SRL models in this manual have 3-Way Emergency Retrieval (see Figure 1) and meet ANSI Z359.14 Class B requirements for Self-Retracting Lanyards with Integral Rescue (SRL-R). They are equipped with a Rescue Hand Crank (F) and Tripod Mounting Bracket (G) for Confined Space Entry and Rescue Retrieval.

Figure 2 – Sealed-Blok™ Self-Retracting Lanyard (SRL) Components

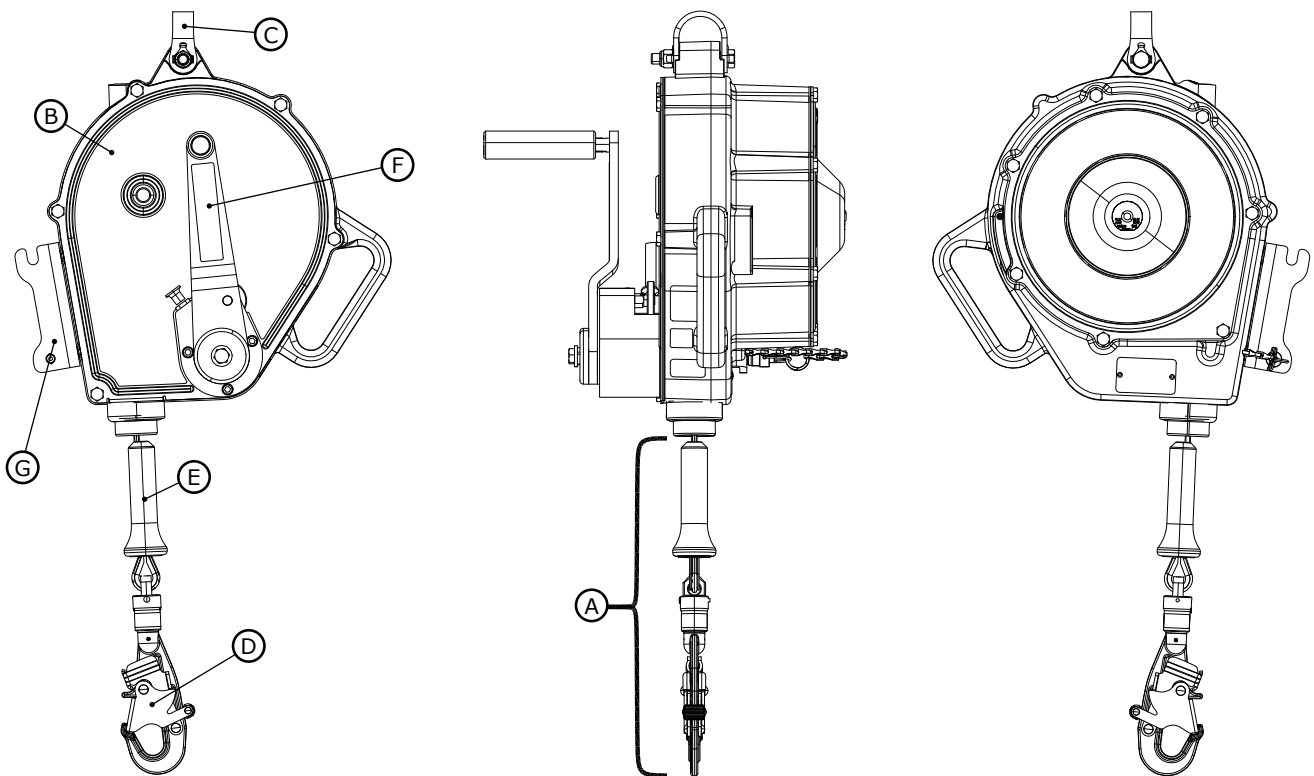

**A - Rope Lifeline B - Housing C - Anchorage Handle D - Self-Locking Snap Hook E - Bumper
F - Rescue Hand Crank G - Mounting Bracket**

⚠ CAUTION: If you remove the Tripod Mounting Bracket from the SRL, DO NOT reinstall the three Mounting Bracket Bolts. Without the added thickness of the bracket, the bolts will interfere with internal function of the unit.

1.0 APPLICATIONS

- 1.1 PURPOSE:** Capital Safety Self-Retracting Lanyards (SRLs) are designed to be a component in a personal fall arrest system (PFAS). Figure 1 illustrates SRLs covered by this instruction manual and their typical applications. They may be used in most situations where a combination of worker mobility and fall protection is required (i.e. inspection work, general construction, maintenance work, oil production, confined space work, etc.).
- 1.2 STANDARDS:** Your SRL conforms to the national or regional standard(s) identified on the front cover of these instructions.
- 1.3 TRAINING:** This equipment is intended to be used by persons trained in its correct application and use. It is the responsibility of the user to assure they are familiar with these instructions and are trained in the correct care and use of this equipment. Users must also be aware of the operating characteristics, application limits, and the consequences of improper use.
- 1.4 LIMITATIONS:** Always consider the following limitations when installing or using this equipment:

⚠ WARNING: Failure to observe the following limitations may result in injury or death.

- **Capacity:** This SRL has been compliance tested for use by one person with a combined weight (clothing, tools, etc.) from 130 lbs (59 kg) to 310 lbs (141 kg).¹ Make sure all of the components in your system are rated to a capacity appropriate to your application.
- **Anchorage:** Anchorages selected for fall arrest systems shall have a strength capable of sustaining static loads applied in the directions permitted by the system of at least:
 1. 5,000 lbs. (22.2 kN) for non-certified anchorages, or
 2. Two times the maximum arresting force for certified anchorages.

When more than one fall arrest system is attached to an anchorage, the strengths set forth in (1) and (2) above shall be multiplied by the number of systems attached to the anchorage.

① FROM OSHA 1926.500 AND 1910.66: Anchorages used for attachment of personal fall arrest systems shall be independent of any anchorage being used to support or suspend platforms, and capable of supporting at least 5,000 lbs. per user attached, or be designed, installed, and used as part of a complete personal fall arrest systems which maintains a safety factor of at least two, and is under the supervision of a qualified person.

- **Locking Speed:** Situations which do not allow for an unobstructed fall path should be avoided. Working in confined or cramped spaces may not allow the body to reach sufficient speed to cause the SRL to lock if a fall occurs. Working on slowly shifting material, such as sand or grain, may not allow enough speed buildup to cause the SRL to lock. A clear path is required to assure positive locking of the SRL.
- **Free fall:** When used correctly, SRLs will limit the free fall distance to 2 ft. (61 cm). To avoid increased fall distances, do not work above the anchorage level. **Do not lengthen SRLs by connecting a lanyard or similar component without consulting Capital Safety.** Never clamp, knot, or prevent the lifeline from retracting or being taut. Avoid slack line.
- **Swing Falls:** Swing Falls occur when the anchorage point is not directly above the point where a fall occurs. The force of striking an object in a swing fall may cause serious injury (see Figure 3A). Minimize swing falls by working as directly below the anchorage point as possible.
- **Fall Clearance:** Figure 3B illustrates Fall Clearance. SRL Fall Arrest Systems should have a minimum Fall Clearance of 6 ft (2 m) for falls from a standing position where the SRL is anchored directly overhead. Falls from a kneeling or crouching position will require an additional 3 ft (1 m) of Fall Clearance. In a swing fall situation, the total vertical fall distance will be greater than if the user had fallen directly below the anchorage point and may require additional Fall Clearance. The table in Figure 3 provides the minimum vertical Fall Clearance needed below the working level of the SRL user where added Swing Fall distance is within the recommended range of use.
- **Hazards:** Use of this equipment in areas where surrounding hazards exist may require additional precautions to reduce the possibility of injury to the user or damage to the equipment. Hazards may include, but are not limited to: high heat, caustic chemicals, corrosive environments, high voltage power lines, explosive or toxic gases, moving machinery, or overhead materials that may fall and contact the user or fall arrest system. Avoid working where your lifeline may cross or tangle with that of another worker. Avoid working where an object may fall and strike the lifeline; resulting in loss of balance or damage to the lifeline. Do not allow the lifeline to pass under arms or between legs.
- **Sharp Edges:** Avoid working where the lifeline will be in contact with or abrade against unprotected sharp edges. Where contact with a sharp edge is unavoidable, cover the edge with a protective material.

¹ **Capacity:** 130 lbs - 310 lbs (59 kg - 141 kg) is the capacity range required by standard ANSI Z359.14. Some DBI-SALA SRLs are tested to a 420 lbs (191 kg) capacity. See Figure 1 for the SRL models covered by this instruction and their capacities.

Figure 3 – Fall Clearance and Swing Fall

FC = Minimum Fall Clearance

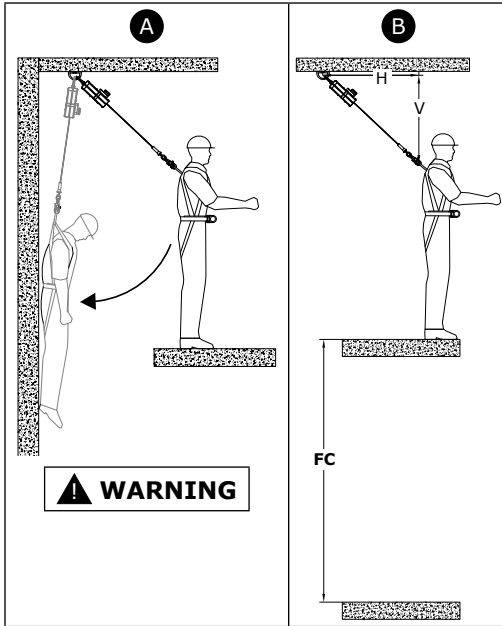

FC ft (m)	H - Horizontal Distance from Anchorage Point										
	0 (0.0)	2 (0.6)	4 (1.2)	6 (1.8)	8 (2.4)	10 (3.0)	12 (3.7)	14 (4.3)	16 (4.9)	18 (5.5)	20 (6.1)
0 (0.0)	6 (2)	8 (2.6)	x	x	x	x	x	x	x	x	x
10 (3)	6 (2)	6.2 (2.1)	6.8 (2.3)	7.7 (2.6)	8.8 (2.9)	x	x	x	x	x	x
20 (6.1)	6 (2)	6.1 (2)	6.4 (2.1)	6.9 (2.3)	7.5 (2.5)	8.4 (2.7)	9.3 (3)	x	x	x	x
30 (9.1)	6 (2)	6.1 (2.1)	6.3 (2.1)	6.6 (2.2)	7 (2.3)	7.6 (2.5)	8.3 (2.7)	9.1 (3)	x	x	x
40 (12.2)	6 (2)	6 (2)	6.2 (2.1)	6.4 (2.1)	6.8 (2.2)	7.2 (2.4)	7.8 (2.5)	8.4 (2.7)	9.1 (3)	9.9 (3.2)	x
50 (15.2)	6 (2)	6 (2)	6.2 (2.1)	6.4 (2.2)	6.6 (2.2)	7 (2.3)	7.4 (2.5)	7.9 (2.6)	8.5 (2.8)	9.1 (3)	9.9 (3.2)
60 (18.3)	6 (2)	6 (2)	6.1 (2)	6.3 (2.1)	6.5 (2.2)	6.8 (2.4)	7.2 (2.5)	7.6 (2.6)	8.1 (2.8)	8.6 (3)	9.2 (3.2)
70 (21.3)	6 (2)	6 (2)	6.1 (2.1)	6.3 (2.1)	6.5 (2.2)	6.7 (2.2)	7 (2.3)	7.4 (2.5)	7.8 (2.6)	8.3 (2.7)	8.8 (2.9)
80 (24.4)	6 (2)	6 (2)	6.1 (2)	6.2 (2)	6.4 (2.1)	6.6 (2.3)	6.9 (2.3)	7.2 (2.5)	7.6 (2.6)	8 (2.6)	8.5 (2.7)
90 (27.4)	6 (2)	6 (2)	6.1 (2.1)	6.2 (2.1)	6.4 (2.2)	6.6 (2.3)	6.8 (2.3)	7.1 (2.4)	7.4 (2.5)	7.8 (2.6)	8.2 (2.7)
100 (30.5)	6 (2)	6 (2)	6.1 (2)	6.2 (2)	6.3 (2.1)	6.5 (2.2)	6.7 (2.3)	7 (2.4)	7.3 (2.4)	7.6 (2.5)	8 (2.6)
110 (33.5)	6 (2)	6 (2)	6.1 (2.1)	6.2 (2.1)	6.3 (2.2)	6.5 (2.2)	6.7 (2.3)	6.9 (2.4)	7.2 (2.4)	7.5 (2.5)	7.8 (2.6)
120 (36.6)	6 (2)	6 (2)	6.1 (2)	6.1 (2)	6.3 (2.1)	6.4 (2.2)	6.6 (2.2)	6.8 (2.3)	7.1 (2.4)	7.3 (2.4)	7.7 (2.5)
130 (39.6)	6 (2)	6 (2)	6.1 (2.1)	6.1 (2.1)	6.2 (2.1)	6.4 (2.2)	6.6 (2.3)	6.8 (2.3)	7 (2.4)	7.2 (2.4)	7.5 (2.5)
140 (42.7)	6 (2)	6 (2)	6.1 (2)	6.1 (2)	6.2 (2)	6.4 (2.1)	6.5 (2.2)	6.7 (2.2)	6.9 (2.3)	7.2 (2.3)	7.4 (2.4)
150 (45.7)	6 (2)	6 (2)	6.1 (2.1)	6.1 (2.1)	6.2 (2.1)	6.3 (2.2)	6.5 (2.2)	6.7 (2.3)	6.9 (2.4)	7.1 (2.4)	7.3 (2.4)
160 (48.8)	6 (2)	6 (2)	6 (2)	6.1 (2)	6.2 (2)	6.3 (2.1)	6.4 (2.2)	6.6 (2.2)	6.8 (2.3)	7 (2.3)	7.2 (2.3)
170 (51.8)	6 (2)	6 (2)	6 (2)	6.1 (2)	6.2 (2.1)	6.3 (2.1)	6.4 (2.2)	6.6 (2.3)	6.8 (2.3)	7 (2.3)	7.2 (2.4)
180 (54.9)	6 (2)	6 (2)	6 (2)	6.1 (2)	6.2 (2)	6.3 (2.1)	6.4 (2.1)	6.5 (2.2)	6.7 (2.2)	6.9 (2.2)	7.1 (2.3)
190 (57.9)	6 (2)	6 (2)	6 (2)	6.1 (2)	6.2 (2.1)	6.3 (2.1)	6.4 (2.1)	6.5 (2.2)	6.7 (2.2)	6.9 (2.3)	7 (2.3)

x Added Swing Fall Length is not within the recommended work zone.

NOTE: Fall Clearance (FC) values in the above table assume a fall from a standing position. If the worker is kneeling or crouching near an edge when a fall occurs, an additional 3 ft (1 m) of Fall Clearance is needed.

2.0 USE

- 2.1 FALL PROTECTION AND RESCUE PLAN:** The employer must have a Fall Protection and Rescue Plan in place that meets *ANSI Z359.2 Minimum Requirements for a Comprehensive Managed Fall Protection Program*. The plan should provide guidelines and requirements for an employer’s managed fall protection program, including policies, duties and training; fall protection procedures; eliminating and controlling fall hazards; rescue procedures; incident investigations; and evaluating program effectiveness.
- 2.2 INSPECTION FREQUENCY:** SRLs shall be inspected by the authorized person¹ or rescuer² before each use (See Table 2). Additionally, inspections shall be conducted by a competent person³ other than the user. Extreme working conditions (harsh environment, prolonged use, etc.) may necessitate more frequent competent person inspections. The competent person shall use the Inspection Schedule (Table 1) to determine appropriate inspection intervals. Inspection procedures are described in the *“Inspection Checklist”* (Table 2). Results of the Competent Person inspection should be recorded in the *“Inspection and Maintenance Log”* on the back pages of these instructions or recorded with the i-Safe™ system (see Section 5).
- 2.3 NORMAL OPERATIONS:** Normal operation will allow the lifeline to extend and retract with no hesitation or slack as the worker moves at normal speeds. If a fall occurs, a speed sensing brake system will activate, stopping the fall and absorbing much of the energy created. Sudden or quick movements should be avoided during normal work operation, as this may cause the SRL to lock up. For falls which occur near the end of the lifeline travel, a reserve lifeline system or Energy Absorber has been incorporated to reduce the fall arrest forces.

⚠ WARNING: If the SRL has been subjected to fall arrest forces: remove it from service, mark or tag as *“UNUSABLE”*, inspect and service as instructed in Sections 5 and 6. Continued use of the SRL after fall arrest may result in injury or death.

1 Authorized Person: A person assigned by the employer to perform duties at a location where the person will be exposed to a fall hazard.
2 Rescuer: Person or persons other than the rescue subject acting to perform an assisted rescue by operation of a rescue system.
3 Competent Person: An individual designated by the employer to be responsible for the immediate supervision, implementation, and monitoring of the employer’s managed fall protection program who, through training and knowledge, is capable of identifying, evaluating, and addressing existing and potential fall hazards, and who has the employer’s authority to take prompt corrective action with regard to such hazards.

Table 1 – Inspection Schedule

Type of Use	Application Examples	Conditions of Use	Inspection Frequency
			Competent Person
Infrequent to Light	Rescue and Confined Space, Factory Maintenance	Good Storage Conditions, Indoor or Infrequent Outdoor Use, Room Temperature, Clean Environments	Annually
Moderate to Heavy	Transportation, Residential Construction, Utilities, Warehouse	Fair Storage Conditions, Indoor and Extended Outdoor Use, All Temperatures, Clean or Dusty Environments	Semi-Annually to Annually
Sever to Continuous	Commercial Construction, Oil and Gas, Mining	Harsh Storage Conditions, Prolonged or Continuous Outdoor Use, All Temperatures, Dirty Environment	Quarterly to Semi-Annually

2.4 BODY SUPPORT: A Full Body Harness must be used with the Self-Retracting Lanyard. The harness connection point must be above the user’s center of gravity. A body belt is not authorized for use with the Self-Retracting Lanyard. If a fall occurs when using a body belt it may cause unintentional release or physical trauma from improper body support.

2.5 COMPATIBILITY OF COMPONENTS: Unless otherwise noted, Capital Safety equipment is designed for use with Capital Safety approved components and subsystems only. Substitutions or replacements made with non approved components or subsystems may jeopardize compatibility of equipment and may affect safety and reliability of the complete system.

① **IMPORTANT:** Follow manufacturer’s instructions for components and subsystems in your personal fall arrest system.

2.6 COMPATIBILITY OF CONNECTORS: Connectors are considered to be compatible with connecting elements when they have been designed to work together in such a way that their sizes and shapes do not cause their gate mechanisms to inadvertently open regardless of how they become oriented. Contact Capital Safety if you have any questions about compatibility. Connectors (hooks, carabiners, and D-rings) must be capable of supporting at least 5,000 lbs. (22.2 kN). Connectors must be compatible with the anchorage or other system components. Do not use equipment that is not compatible. Non-compatible connectors may unintentionally disengage (see Figure 4). Connectors must be compatible in size, shape, and strength. Self-locking snap hooks and carabiners are required.

2.7 MAKING CONNECTIONS: Snap hooks and carabiners used with this equipment must be self-locking. Ensure all connections are compatible in size, shape and strength. Do not use equipment that is not compatible. Ensure all connectors are fully closed and locked. Capital Safety connectors (snap hooks and carabiners) are designed to be used only as specified in each product’s user’s instructions. See Figure 5 for examples of inappropriate connections. Do not connect snap hooks and carabiners:

- A. To a D-ring to which another connector is attached.
- B. In a manner that would result in a load on the gate.

① **NOTE:** Large throat snap hooks should not be connected to standard size D-rings or similar objects which will result in a load on the gate if the hook or D-ring twists or rotates, unless the snap hook is equipped with a 3,600 lb (16 kN) gate. Check the marking on your snap hook to verify that it is appropriate for your application.

- C. In a false engagement, where size or shape of the mating connectors are not compatible and, without visual confirmation, the connectors seem fully engaged.
- D. To each other.
- E. Directly to webbing or rope lanyard or tie-back (unless the manufacturer’s instructions for both the lanyard and connector specifically allows such a connection).
- F. To any object which is shaped or dimensioned such that the snap hook or carabiner will not close and lock, or that roll-out could occur.
- G. In a manner that does not allow the connector to align properly while under load.

Figure 4 – Unintentional Disengagement

Figure 5 – Inappropriate Connections

If the connecting element to which a snap hook (shown) or carabiner attaches is undersized or irregular in shape, a situation could occur where the connecting element applies a force to the gate of the snap hook or carabiner. This force may cause the gate (of either a self-locking or a non-locking snap hook) to open, allowing the snap hook or carabiner to disengage from the connecting point.

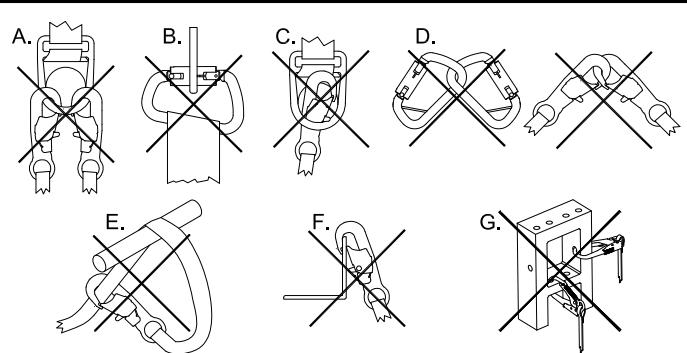
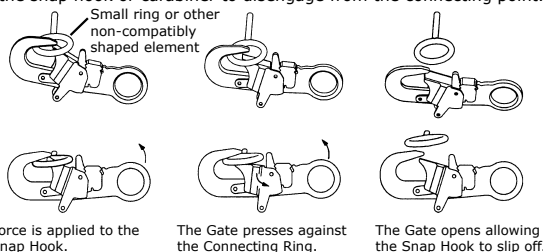

3.0 INSTALLATION

- 3.1 PLANNING:** Plan your fall protection system before starting your work. Account for all factors that may affect your safety before, during, and after a fall. Consider all requirements and limitations defined in this manual.
- 3.2 ANCHORAGE:** Figure 6 illustrates typical SRL anchorage connections. The anchorage should be directly overhead to minimize Free Fall and Swing Fall hazards (see Section 2). Select a rigid anchorage point capable of sustaining the static loads defined in Section 2.2. Some industries, including the oil and gas industry require secondary Dropped Object Anchorage to prevent the SRL from dropping if the primary anchorage point fails. Sealed-Blok SRLs include a Tie-Off Adaptor and Carabiner for this purpose.
- 3.3 HARNESS CONNECTION:** A Full Body Harness is required for Fall Arrest applications. Connect the Snap Hook on the SRL Lifeline to the Back Dorsal D-Ring on the Full Body Harness. (see Figure 7). For situations such as ladder climbing, it may be useful to connect to the front Sternal D-Ring. Consult the harness manufacturer's instructions for details regarding use of the harness connection points.
- 3.4 TRIPOD MOUNTING:** Figure 8 illustrates installation of the Sealed-Blok Self-Retracting Lanyard with Retrieval Hand-Crank (SRL-R) on a DBI-SALA Tripod. The SRL-R is mounted on a leg of the Tripod and the Lifeline is routed through a Pulley System on the Head of the Tripod:

- 1. Secure the Quick Mount Bracket on the leg of the Tripod:** Assemble the Quick Mount Bracket around the Upper Tube of the Tripod Leg. Position as desired and then tighten the mounting bolts to 15 ft-lbs (20 Nm). Do not overtighten the bolts.

① **IMPORTANT:** Never mount the Quick Mount Bracket on the Lower (Telescoping) Tube of the Tripod Leg.

- 2. Secure the SRL Mounting Bracket on the Quick Mount Bracket:** Position the notches in the SRL Mounting Bracket over the Rod Ends protruding from the Quick Mount Bracket and then pivot the SRL toward the Tripod Leg until the holes in the SRL Mounting Bracket align with the holes in the Quick Mount Bracket. Insert the Mounting Pin through the holes in the SRL Mounting Bracket and Quick Mount Bracket.
- 3. Route the SRL Lifeline over the Tripod Head Mount Pulleys:** Remove the two Retainer Pins from the Head Mount. Position the SRL Lifeline cable in the grooves in the two Head Mount Pulleys. Reinsert the Retainer Pins through the Head Mount.

Figure 6 – Anchorage Connections

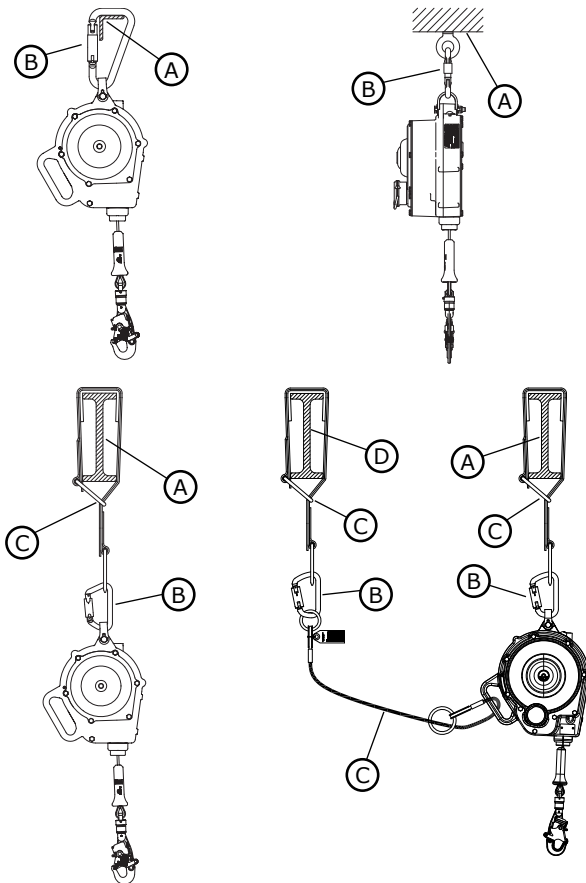

A - Anchorage B - Carabiner C - Tie-Off Adaptor
D - Dropped Object Anchorage

Figure 7 – SRL Connections

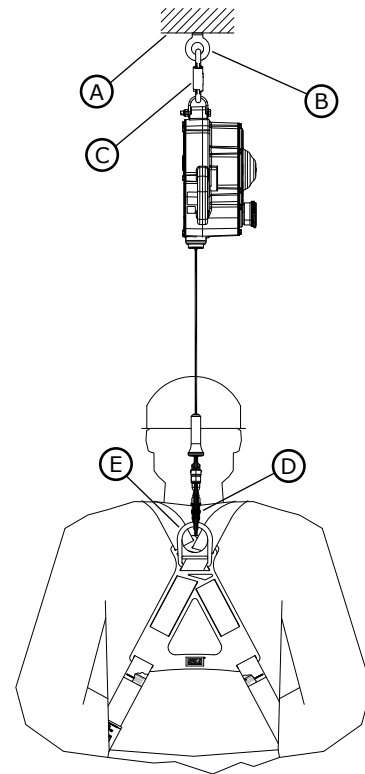

A - Anchorage B - Anchorage Connector C - Connector (Carabiner) D - Snap Hook E - Dorsal D-Ring

Figure 8 – Tripod Mounting

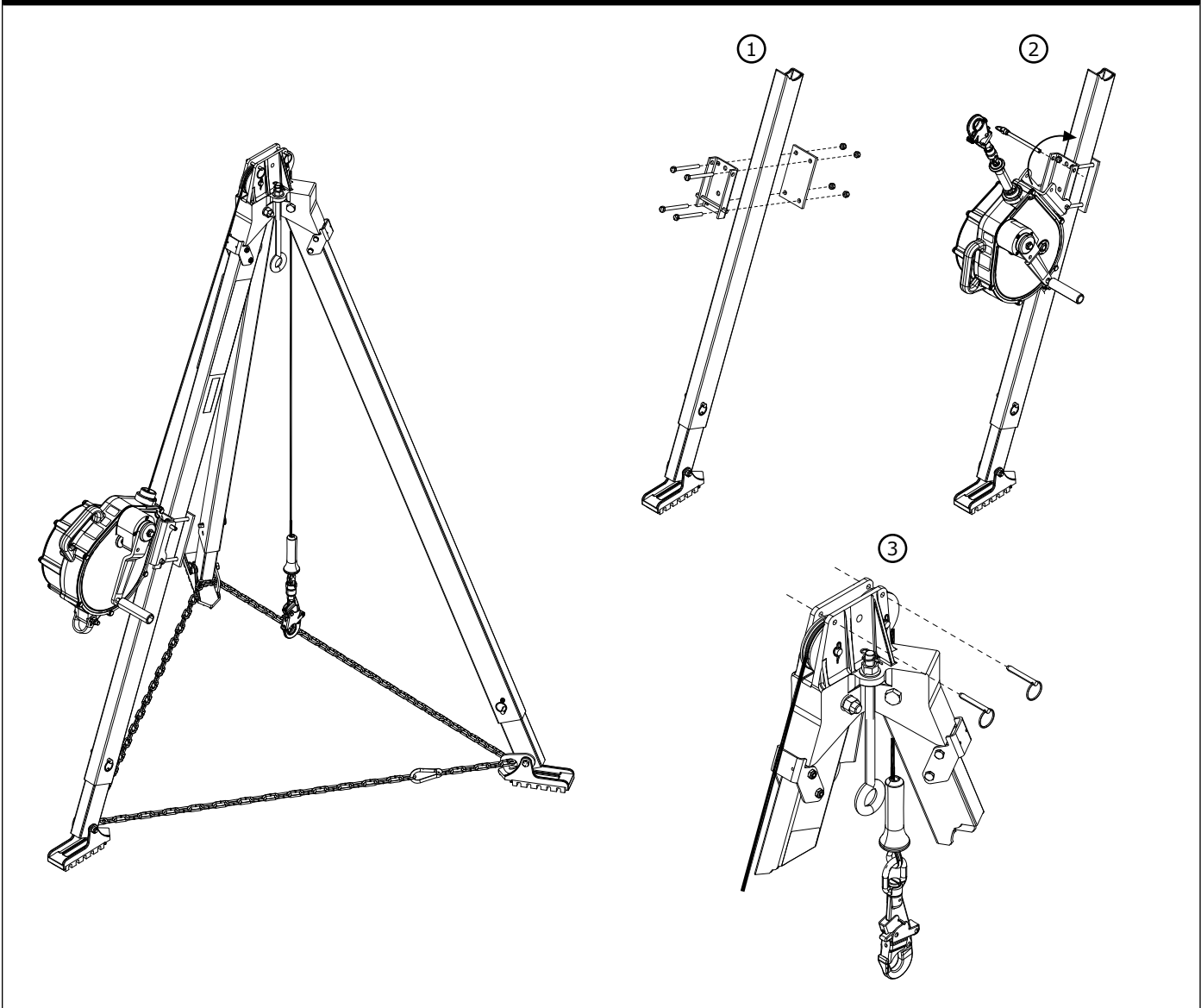

4.0 OPERATION

⚠ WARNING: Do not alter or intentionally misuse this equipment. Consult Capital Safety when using this equipment in combination with components or subsystems other than those described in this manual. Some subsystem and component combinations may interfere with the operation of this equipment. Use caution when using this equipment around electrical hazards, chemical hazards, sharp edges, moving equipment that could hit the user or catch the lifeline, or overhead materials that may fall onto the lifeline. Do not loop the lifeline around small structural members. Failure to heed this warning may result in equipment malfunction, serious injury, or death.

⚠ WARNING: Consult your doctor if there is reason to doubt your fitness to safely absorb the shock from a fall arrest. Age and fitness seriously affect a worker's ability to withstand falls. Pregnant women or minors must not use DBI-SALA Self-Retracting Lanyards.

4.1 BEFORE EACH USE: Before each use of this fall protection equipment carefully inspect it to assure it is in good working condition. Check for worn or damaged parts. Ensure all bolts are present and secure. Check that the lifeline is retracting properly by pulling out the line and allowing it to slowly retract. If there is any hesitation in retraction the unit should be marked as "UNUSABLE" and inspected and serviced per Sections 5 and 6. Inspect the lifeline for cuts, frays, burns, crushing and corrosion. Check locking action by pulling sharply on the line. See Section 5 for inspection details. Do not use if inspection reveals an unsafe condition.

4.2 AFTER A FALL: Any equipment which has been subjected to the forces of arresting a fall or exhibits damage consistent with the effect of fall arrest forces; must be removed from service immediately, marked as "UNUSABLE", and inspected and serviced per the instructions in Sections 5 and 6.

4.3 BODY SUPPORT: A full body harness must be worn when using DBI-SALA SRLs. For general fall protection use, connect to the back Dorsal D-Ring. For situations such as ladder climbing, it may be useful to connect to the front Sternal D-Ring. Consult the harness manufacturer's instructions for details regarding use of the harness connection points.

ⓘ **IMPORTANT:** Do not use a body belt for free fall applications. See OSHA 1926.502 for guidelines.

4.4 MAKING CONNECTIONS: When using a hook to make a connection, ensure roll-out cannot occur (see Figure 5). Do not use hooks or connectors that will not completely close over the attachment object. Do not use non-locking snap hooks. The mounting surface should meet the anchorage strength requirements stated in section 2.2. Follow the manufacturer's instructions supplied with each system component.

4.5 OPERATION: Inspect the SRL as described in Section 5. Connect the SRL to a suitable anchorage or anchorage connector as previously described. Connect the Self-Locking Snap Hook on the end of the lifeline to the Dorsal D-Ring on the Full Body Harness (see Figure 7). Ensure connections are compatible in size, shape, and strength. Ensure hook is fully closed and locked. Once attached, the worker is free to move about within the recommended working area at normal speeds. When working with an SRL, always allow the lifeline to recoil back into the device under control. A tag line may be required to extend or retract the lifeline during connection and disconnection operations. A tag line can be used to prevent uncontrolled retraction of the lifeline into the SRL. Depending on the work site environment and conditions, it may be necessary to restrain the free end of the tag line to prevent interference and entanglement with equipment or machinery.

⚠ **CAUTION:** Do not tie or knot lifeline. Avoid lifeline contact with sharp edges, hard edges (angle iron, I-beam, etc.), or abrasive surfaces. Inspect lifeline frequently for cuts, fraying, burns, or signs of chemical damage. Dirt, contaminants, and water can lower dielectric properties of the lifeline. Use caution near power lines.

4.6 RETRIEVAL OPERATION: Figure 9 illustrates operation of the Integral Rescue Hand Crank on Sealed-Blok Retrieval SRL-Rs. To activate Retrieval mode and use the Rescue Hand Crank:

1. Loosen the Locking Thumb Screw to release the Crank Arm.
2. Rotate the Retrieval Handle up from the SRL Body 90°.
3. Pull and hold the Shift Knob in the unlocked position.
4. Push the Crank Arm in and release the Shift Knob to engage. If needed, rotate the Crank Arm clockwise to help engage the gear.
5. Raise and lower the Lifeline as illustrated in Figure 9
 - A. To Raise: Rotate the Crank Arm counterclockwise.
 - B. To Lower: Rotate the Crank Arm clockwise. After Fall Arrest; crank the Crank Arm counterclockwise slightly first to release the Fall Arrest Brake, then crank the Crank Arm clockwise.

ⓘ **RETRIEVAL OVERLOAD:** Sealed-Blok SRL-Rs do not incorporate an Overload Clutch to limit the force exerted on the drive components and attached person. Avoid line slack while in Retrieval mode. Also, monitor the individual during retrieval to ensure they are not subjected to excessive force from continued lifting after entanglement on an obstruction.

ⓘ **NOTE:** A minimum load of 75 lbs (33.9 kg) is required to lower or pay out the Lifeline. A force of 30 lbs (0.13 kN) is required to operate the Retrieval system when loaded to capacity.

⚠ **CAUTION:** Stop cranking when the Lifeline is fully extended or retracted. Continued cranking can damage components.

4.7 RETRIEVAL DISENGAGEMENT: To disengage Retrieval mode:

⚠ **CAUTION:** When Retrieval mode is disengaged, any extended Lifeline will retract into the SRL. To avoid possible injury, retract the Lifeline prior to disengagement or hold onto the Lifeline.

1. Remove any load from the Lifeline.
2. Pull and hold the Shift Knob in the unlocked position.
3. Pull the Crank Arm out to disengage and then release the Shift Knob.
4. Pull out and rotate the Retrieval Handle down toward the SRL Body to stowed position.

Figure 9 – Retrieval Operation

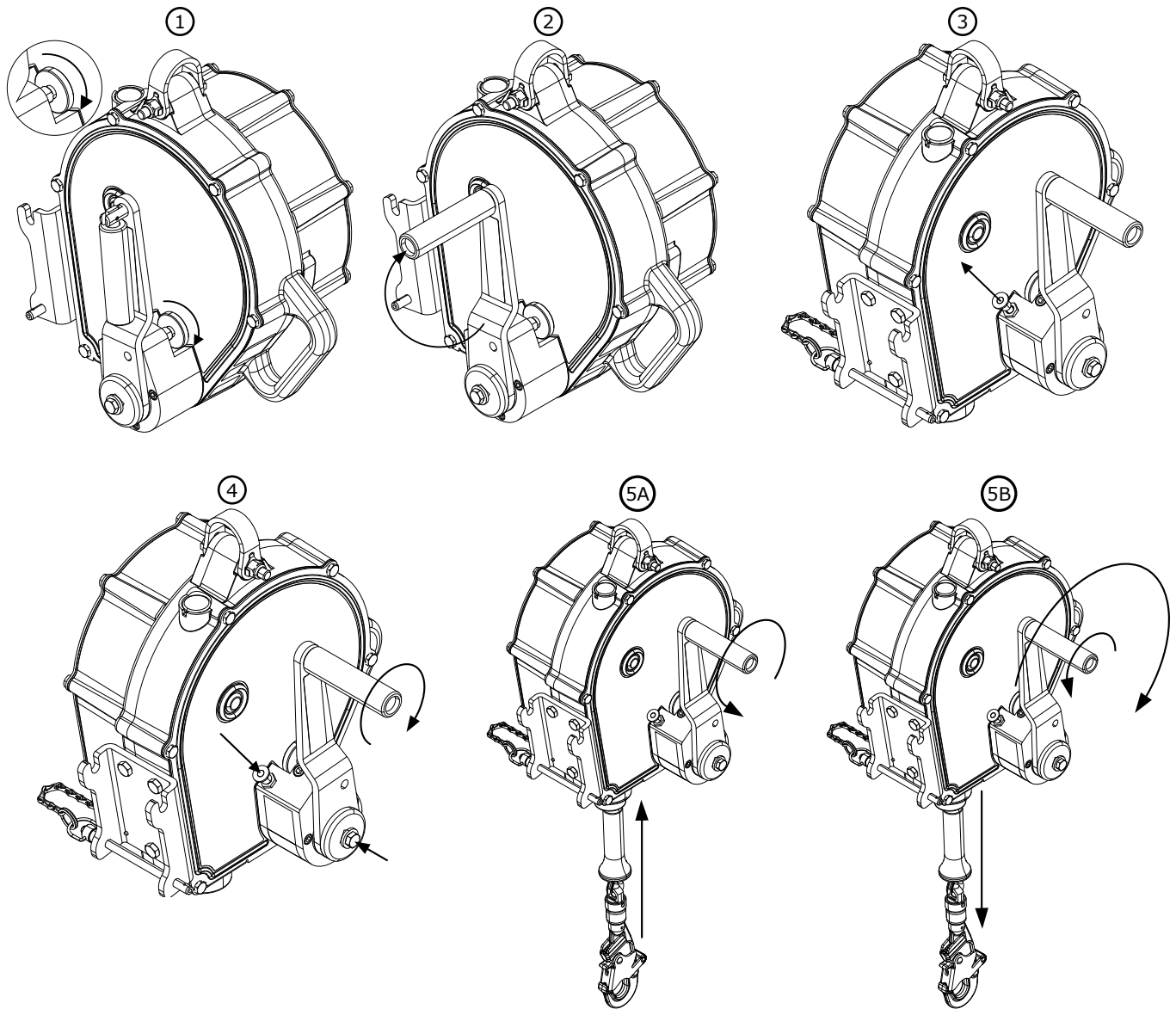

5.0 INSPECTION

5.1 i-Safe™ RFID TAG: The Self-Retracting Lanyard includes an i-Safe™ Radio Frequency Identification (RFID) tag. The RFID tag can be used in conjunction with the i-Safe handheld reading device and web based portal to simplify inspection and inventory control and provide records for your fall protection equipment. For details, contact a Capital Safety Customer Service representative (see back cover); or if you have already registered, go to <http://isafe3.capitalsafety.com/Pro/>. Follow the instructions provided with your i-Safe handheld reader, or on the web portal, to transfer your data to your web log.

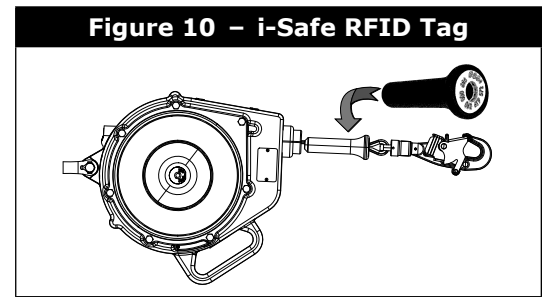

5.2 INSPECTION : The Sealed-Blok Self-Retracting Lanyard must be inspected at the intervals defined in Section 2.2 - Inspection Frequency". Inspection procedures are described in the "Inspection Checklist" (Table 2) at the back of this manual.

⚠ WARNING: If the Self-Retracting Lanyard has been subjected to fall arrest or impact forces: remove from service immediately, mark as "UNUSABLE", and contact Capital Safety for service options. Continued use of the SRL after fall arrest may result in injury or death.

① IMPORTANT: Extreme working conditions (harsh environments, prolonged use, etc.) may require increasing the frequency of inspections.

5.3 UNSAFE OR DEFECTIVE CONDITIONS: If inspection per the Inspection Checklist (Table 2) reveals an unsafe or damaged condition, remove the Self-Retracting Lanyard from service immediately, mark as "UNUSABLE", and contact Capital Safety for service options.

⚠ WARNING: Continued use of fall protection equipment with an unsafe or damaged condition may result in injury or death.

① NOTE: Only Capital Safety or parties authorized in writing may make repairs to this equipment.

5.4 PRODUCT LIFE: The functional life of DBI-SALA Self-Retracting Lanyards is determined by work conditions and maintenance. As long as the product passes inspection criteria, it may remain in service.

6.0 CLEANING, SERVICE, STORAGE, AND TRANSPORT

6.1 CLEANING: Cleaning procedures for the Self-Retracting Lanyard are as follows:

- Periodically clean the exterior of the SRL using water and a mild soap solution. Position the SRL so excess water can drain out. Clean labels as required.
- Clean lifeline with water and mild soap solution. Rinse and thoroughly air dry. Do not force dry with heat. An excessive buildup of dirt, paint, etc. may prevent the lifeline from fully retracting back into the housing causing a potential free fall hazard. Replace lifeline if excessive buildup is present.

6.2 SERVICE: Sealed-Blok Rope Self-Retracting Lanyards do not have FAST-Line Replacable Lifelines. Lifeline replacement and all other service must be completed by an authorized service center. Do not attempt to disassemble the SRL or lubricate any parts.

6.3 STORAGE AND TRANSPORT: Store and transport Self-Retracting Lanyard in a cool, dry, clean environment out of direct sunlight. Avoid areas where chemical vapors may exist. Thoroughly inspect the SRL after any period of extended storage.

Table 2 – Inspection Checklist

Component:	Inspection:	Authorized Person or Rescuer	Competent Person
SRL (Diagram 1)	Inspect for loose bolts and bent or damaged parts.	<input type="checkbox"/>	<input type="checkbox"/>
	Inspect Housing (A) for distortion, cracks, or other damage.	<input type="checkbox"/>	<input type="checkbox"/>
	Inspect the Swivel Eye (B) for distortion, cracks, or other damage. The Swivel Eye should be attached securely to the SRL, but should pivot freely.	<input type="checkbox"/>	<input type="checkbox"/>
	The Lifeline (C) should pull out and retract fully without hesitation or creating a slack line condition.	<input type="checkbox"/>	<input type="checkbox"/>
	Ensure device locks up when lifeline is jerked sharply. Lockup should be positive with no slipping.	<input type="checkbox"/>	<input type="checkbox"/>
	The labels must be present and fully legible (see "Labels").	<input type="checkbox"/>	<input type="checkbox"/>
Retrieval Integral Rescue Hand Crank (Diagram 2)	Look for signs of corrosion on the entire unit.	<input type="checkbox"/>	<input type="checkbox"/>
	Inspect the Crank Arm (A) for distortion or other damage. Ensure that the Retrieval Handle (B) can be folded out and secured in the cranking position.	<input type="checkbox"/>	<input type="checkbox"/>
	Ensure the Retrieval Shift Knob (C) can be pulled out to the unlocked position and then released, locking the Crank Arm in both the engaged and disengaged positions.	<input type="checkbox"/>	<input type="checkbox"/>
Swivel Snap Hook & Impact Indicator (Diagram 3)	Test the retrieval feature for proper operation by raising and lowering a test weight of at least 75 lbs (34 kg). When the Retrieval Handle is released, the weight should not move and the Retrieval Handle should remain in position (no movement). A 'clicking' sound should be audible when raising the load.	<input type="checkbox"/>	<input type="checkbox"/>
	Inspect the Swivel Snap Hook for signs of damage, corrosion, and working condition. Swivel should rotate freely. Inspect the Impact Indicator. If the Red Band is displayed (Indicated Mode), impact loading has occurred and the SRL must be removed from service and inspected. Do not attempt to reset the Impact Indicator. Return the SRL to an authorized service center for resetting. NOTE: The Swivel will not turn freely when the Impact Indicator is in Indicated Mode.	<input type="checkbox"/>	<input type="checkbox"/>
Rope Lifeline (Diagram 4)	Inspect rope for abrasion, cut strands, pulled strands, melting or glazing, compression, inconsistent diameter, and discoloration or degradation. Slide the lifeline bumper up and inspect for cut strands.	<input type="checkbox"/>	<input type="checkbox"/>

Diagram 1 – SRL Inspection

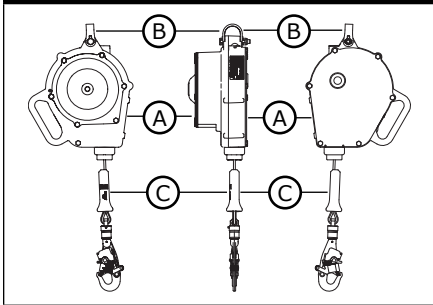

Diagram 3 – Impact Indicator

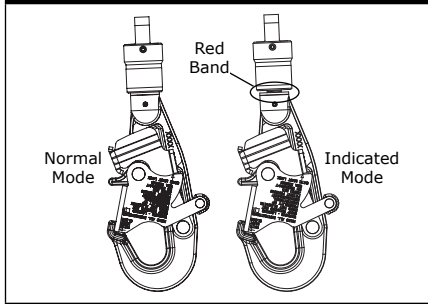

Diagram 4 – Rope

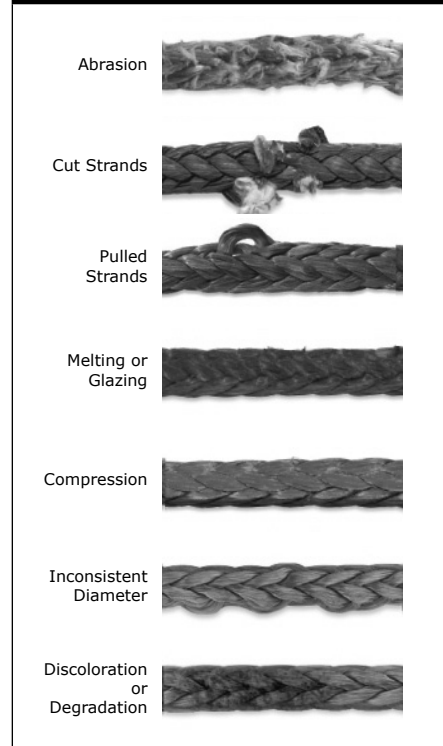
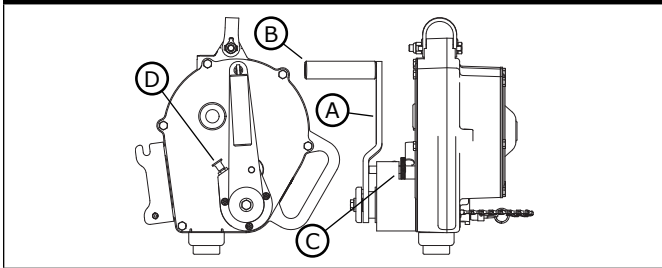

Diagram 2 – Retrieval Components



LABELS

The following labels must be present on the Ultra-Lok SRL. Labels must be replaced if they are not fully legible. Contact Capital Safety for replacement labels.

A

B

C

D

E

SALA www.capitalsafety.com
Capital Safety
Red Wing, MN, USA
+1-800-328-6146

WARNING Read Instructions before use. Manufacturer's Instructions supplied with this product at time of shipment must be followed for proper use, maintenance, and inspection. Alteration or misuse of this product, or failure to follow instructions may result in serious injury or death. See other markings.

USE Anchorage strength requirement 5000 LBS (2224N). Anchor unit as directly above work area as possible to reduce possible swing fall hazard. Do not work above anchorage level. A Full body harness is required for use with this device. Capacity is a single user only. Avoid lifeline contact with sharp edges. For use by trained persons only. This unit is suitable for use with horizontal lifelines. See user manual for additional information including suitability for horizontal use.

IMPACT INDICATOR
Exposed color band indicates impact loading. Remove retractable lifeline from service for inspection if color band is exposed. Refer to user manual for more information.
U.S. PAT. NO. 5,186,289

FAST-Line™ (cable models only)
Units equipped with the DB-SALA FAST-Line™ systems permit a quick and easy field replacement of the lifeline by a competent person, properly trained. Refer to the user manual or contact Capital Safety for more information about FAST-Line™.

INSPECTION Before each use, and at least monthly, inspect in accordance with the user manual, including locking function (pull sharply to test), retraction function, lifeline condition, function and condition of connectors, housing and fasteners, legibility of labels, and any evidence of defects, damage, or missing parts. Inspection by a competent person is required at least annually, see user manual. If used to arrest a fall, remove from service for inspection. Do not use if inspection reveals an unsafe condition.

INSPECTION LOG

DATE	INITIAL	DATE	INITIAL

MATERIAL: OSHA CAPACITY (lb./kg): LENGTH (ft):

ANSI Z359 series	OSHA
Capacity	310 lbs See OSHA CAPACITY
Maximum arresting force	1,350 lbs (6.0 kN) 1,800 lbs (8.0 kN)
Average arresting force	900 lbs (4.0 kN) N/A
Maximum arresting distance	42 in. (1.1 m) 42 in. (1.1 m)

WARNING (RSQ™ MODELS ONLY)
Avoid descending into electrical, thermal, chemical sources or other hazards.
USE The RSQ™ feature of the device is designed for emergency use only. Unit may only be used for single descent. If used to descend, remove from service for inspection.

SPECIFICATIONS
Maximum descent possible is equal to the device length. Nominal descent speed: 3-4 ft/sec. (0.9-1.2 m/sec).

Meets OSHA, ANSI Z359.14 Class B, and ANSI A10.32
ISO17025 accredited verification to ANSI Z359.7

DO NOT REMOVE THIS LABEL PATENTS PENDING

WINCH OPERATION
1) Rotate the locking screw down completely to free the crank arm.
2) Rotate the handle out from the stowed position.
3) To engage winch, pull and hold the shift knob in the unblocked position. Push in the crank arm to the engaged position and release the shift knob. If needed, rotate the crank arm clockwise (downward) to aid in gear engagement.
4) To raise load, crank counterclockwise. To lower load, first crank counterclockwise to release the fall arrest brake, then crank clockwise. NOTE: A minimum load of 75 lbs (33.3 kg) is required for lowering or to pay out line. A force of 30-40 lbs (13.6-18.2 kg) is required to operate when loaded to capacity.
CAUTION: Stop cranking when line is fully extended or retracted. Continued cranking can damage components.
5) To disengage the winch, first remove load from line. Pull and hold the shift knob in the unblocked position. Pull out the crank arm to the disengaged position and release the shift knob. Secure the crank arm with the locking screw. Pull out handle and rotate to the stowed position.
WARNING: Avoid slack line while in rescue mode. Refer to manual supplied with this product for detailed instructions.

Serial No. /N° de série _____

Model No. /N° du modèle _____

Mfrd/Fab. _____

Lot _____

Service Dates / Dates de Réparation

9504631 Rev. C

DB SALA i-safe

This product is i-Safe enabled and contains an electronic tag that can be read by compatible readers – providing inspection logs, inventory management and other safety information.
Ce produit est validé dans i-Safe et contient une rondelle d'identification électronique qui peut être lue par des lecteurs compatibles – en fournissant des registres d'inspection, de l'informations sur la gestion des stocks et d'autre information relative à la protection.
9502313 Rev. C

RAISE/LEVER

CAPACITY: 420 LB
CAPACITÉ: 420 LB

NOT FOR WORK SUPPORT OR POSITIONING.
REFER TO MANUAL.

PAS POUR SOUTENIR OU MAINTENIR LA POSITION DE TRAVAIL. VOIR LE MANUEL.

LOWER/DESCENDRE

LIMITED LIFETIME WARRANTY

Warranty to End User: D B Industries, LLC dba CAPITAL SAFETY USA ("CAPITAL SAFETY") warrants to the original end user ("End User") that its products are free from defects in materials and workmanship under normal use and service. This warranty extends for the lifetime of the product from the date the product is purchased by the End User, in new and unused condition, from a CAPITAL SAFETY authorized distributor. CAPITAL SAFETY'S entire liability to End User and End User's exclusive remedy under this warranty is limited to the repair or replacement in kind of any defective product within its lifetime (as CAPITAL SAFETY in its sole discretion determines and deems appropriate). No oral or written information or advice given by CAPITAL SAFETY, its distributors, directors, officers, agents or employees shall create any different or additional warranties or in any way increase the scope of this warranty. CAPITAL SAFETY will not accept liability for defects that are the result of product abuse, misuse, alteration or modification, or for defects that are due to a failure to install, maintain, or use the product in accordance with the manufacturer's instructions.

CAPITAL SAFETY'S WARRANTY APPLIES ONLY TO THE END USER. THIS WARRANTY IS THE ONLY WARRANTY APPLICABLE TO OUR PRODUCTS AND IS IN LIEU OF ALL OTHER WARRANTIES AND LIABILITIES, EXPRESSED OR IMPLIED. CAPITAL SAFETY EXPRESSLY EXCLUDES AND DISCLAIMS ANY IMPLIED WARRANTIES OF MERCHANTABILITY OR FITNESS FOR A PARTICULAR PURPOSE, AND SHALL NOT BE LIABLE FOR INCIDENTAL, PUNITIVE OR CONSEQUENTIAL DAMAGES OF ANY NATURE, INCLUDING WITHOUT LIMITATION, LOST PROFITS, REVENUES, OR PRODUCTIVITY, OR FOR BODILY INJURY OR DEATH OR LOSS OR DAMAGE TO PROPERTY, UNDER ANY THEORY OF LIABILITY, INCLUDING WITHOUT LIMITATION, CONTRACT, WARRANTY, STRICT LIABILITY, TORT (INCLUDING NEGLIGENCE) OR OTHER LEGAL OR EQUITABLE THEORY.



Global Leader in Fall Protection

Distributed by Engineered Fall Protection

Sales@EngineeredFallProtection.com

www.EngineeredFallProtection.com

Tel: (314) 492-4422

